

iQ300, Telescopic cooker hood, 60 cm, Silver metallic LI64MA531B



A



Optional accessories

LZ111TB14	Clean Air Standard odor filter (repl.)
LZ111TI14	Clean Air Standard recirculation kit
LZ45450	Standard recirculation kit
LZ45510	Standard odor filter (replacement)
LZ46521	Handle strip white
LZ46561	Handle strip black
LZ46850	Design-Handle strip

For clean lines the powerful telescopic cooker hood disappears into an upper cabinet, perfect for modern kitchens.

- ✓ iQdrive motor - The quiet, high-performance motor ensures efficient removal of odours and steam.
- ✓ LED lights: for optimal visibility and ambience while cooking.

Features

Technical Data

Typology:	Pull-out
Length of electrical supply cord:	175.0 cm
Min. required niche size for installation (HxWxD):	162mm x 526.0mm x 290mm mm
Minimum distance above an electric hob:	430 mm
Minimum distance above a gas hob:	650 mm
Weight:	8.0 kg
Control panel:	Electronic
Number of speed settings:	3-stages + intensive setting
Max. air extraction:	268 m³/h
Boost position output recirculating:	353 m³/h
Max. recirculation:	263 m³/h
Boost position air extraction:	400 m³/h
Maximum Air flow:	268 m³/h
Number of lights (Stck):	2
Noise level:	62 dB(A) re 1 pW
Diameter of air outlet:	120 / 150 mm
Grease filter material:	Washable aluminium
EAN code:	4242003880104
Connection Rating:	74 W
Fuse protection:	10 A
Nominal power:	220-240 V
Frequency:	50; 60 Hz
Plug type:	GB plug
Installation type:	Built-in
Delay Shut off modes:	10 min



iQ300, Telescopic cooker hood, 60 cm, Silver metallic LI64MA531B

Features

Features

- Soft touch button control with Electronic display
- 3 x power levels plus intensive setting
- 2 x 1,5W LED
- Efficient BLDC motor
- Automatic intensive revert (6mins)
- Automatic after running (Automatic after running (10 minutes))
- 2 x metal grease filter cassettes

Design

- 60 cm wide
- Silver metallic lacquer
- Handle strip specification: stainless steel with logo
- Filter cover stainless steel, perforated and dishwasher safe

Performance

- Suitable for ducted and re-circulating operation
- For recirculated extraction recirculating kit (accessory) needed
- Energy Efficiency Class: A (at a range of energy efficiency classes from A+++ to D)
- Extraction rate according to EN 61591 ø 15 cm:
 - max. Normal use: 268 m³/h
 - Intensive: 400 m³/h
- Noise level according to EN 60704-3 and EN 60704-2-13 at max. normal use exhaust air: 62 dB(A) re 1 pW
- Noise level according to EN 60704-3 and EN 60704-2-13 exhaust air:
 - Max. normal use: 62 dB(A) re 1 pW
 - Intensive: 69 dB(A) re 1 pW
- Noise max. Normal Level: Noise, max. speed in normal use: 62 dB dB*
- 1 single inlet horizontal, Efficient BLDC motor
- Colour Temperature: 3500 K
- Light Intensity: 294 lux
- Power rating: 74 W
- Average Energy Consumption: 21 kWh/year*
- Blower Efficiency Class: B*
- Lighting Efficiency Class: A*
- Grease Filtering Efficiency Class: C*

Planning and installation information

- Installation: Cupboard 60 cm
- Dimensions (HxWxD): 203 x 598 x 290 mm
- Built-in dimensions (HxWxD): 162 x 526 x 290 mm
- Diameter pipe Ø 150 mm (Ø 120 mm enclosed)
- Electrical cable length 1.75 m

* In accordance with the EU-Regulation No 65/2014

iQ300, Telescopic cooker hood, 60 cm, Silver metallic
LI64MA531B

Dimensioned drawings

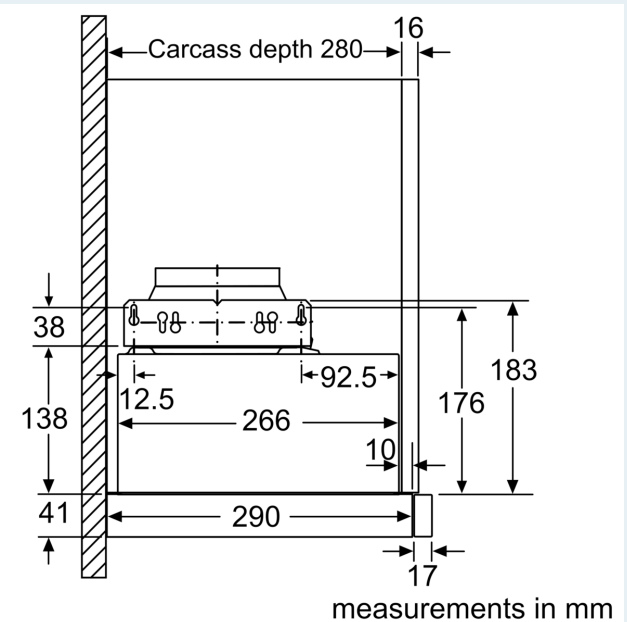
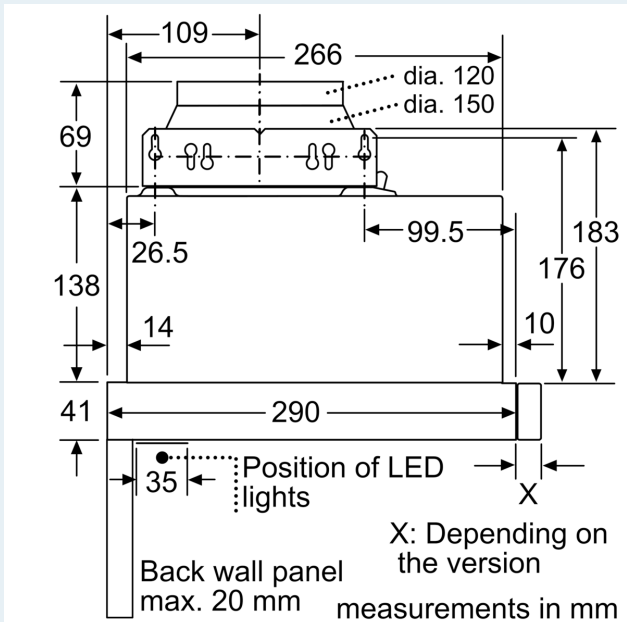
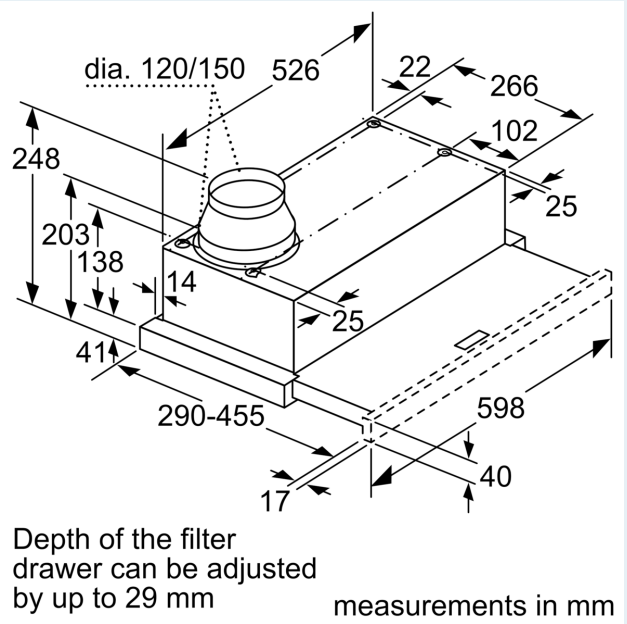
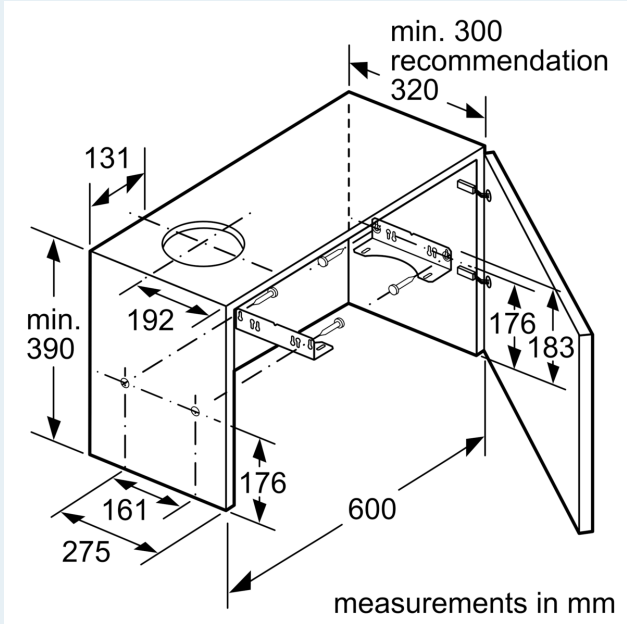

Dimensioned drawings

